

## Canaletta in PE-HD PLUS 300/300 con zanche laterali

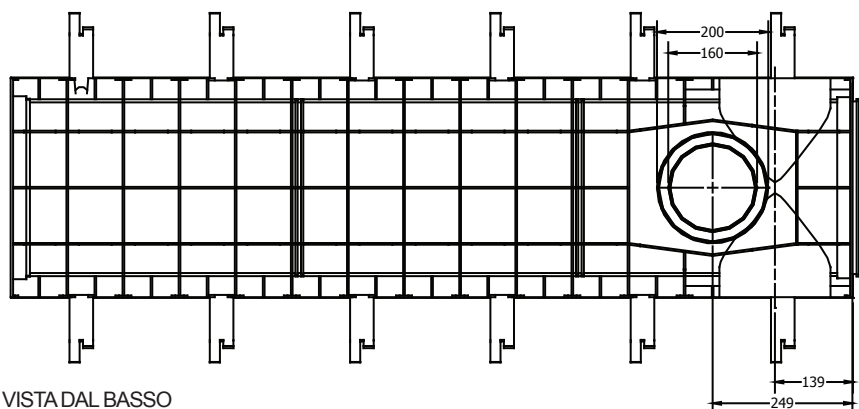

VISTA DAL BASSO

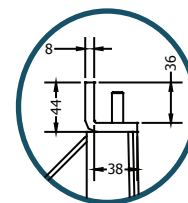

PART. TELAIO

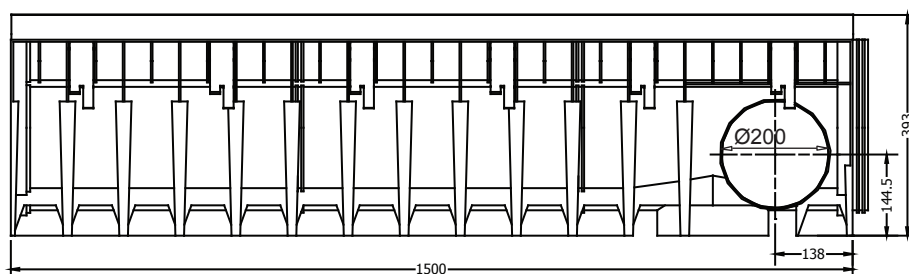

VISTA FRONTALE

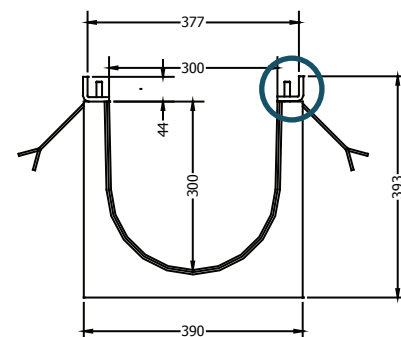

VISTA LATERALE

Tenuta all'acqua: per assicurare la tenuta stagna delle canalette, si consiglia l'utilizzo di un adesivo sigillante bituminoso. A garanzia completa e duratura dell'assenza di perdite attraverso i giunti delle canalette, si può provvedere alla saldatura a caldo dei giunti stessi.

## Scheda Tecnica

### Dimensioni e caratteristiche

N.B. Le dimensioni ed i pesi sono soggetti alle normali tolleranze di fabbricazione

Lunghezza (mm)	1500
Larghezza esterna (mm)	390
Altezza esterna (mm)	393
Luce interna (mm)	300
Altezza interna (mm)	300
Scarichi	3 x Ø200 e 1 x Ø160
Materiale telaio	acciaio zincato/ghisa
Materiale zanca	acciaio zincato
Materiale canaletta	PE-HD
Peso (kg)	28.90
Sezione di drenaggio (cm <sup>2</sup> )	796.0

## Griglie

Maglia 33x19	in acciaio zincato	Classe C250
Maglia	in ghisa sferoidale	Classe C250, D400, E600, F900
Fessura	in ghisa sferoidale	Classe F900
Copertura cieca	in ghisa sferoidale	Classe E600

Il prodotto deve essere posto in opera secondo le specifiche della MufleSystem srl, le istruzioni sono disponibili sul nostro sito internet.

# MUFLEDRAIN

## PLUS

**MUFLE**  
SISTEMI DI DRENAGGIO ACQUA



Code  
504025

rev. 00

### Channel in HD-PE PLUS 300/300 NEW with galvanized steel or ductile iron edge

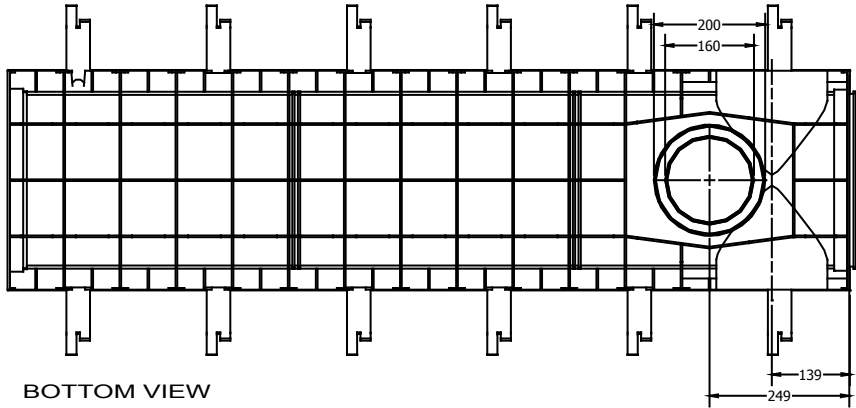

BOTTOM VIEW

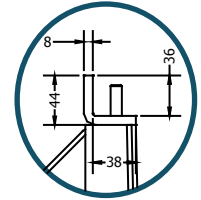

DETAIL SECTION

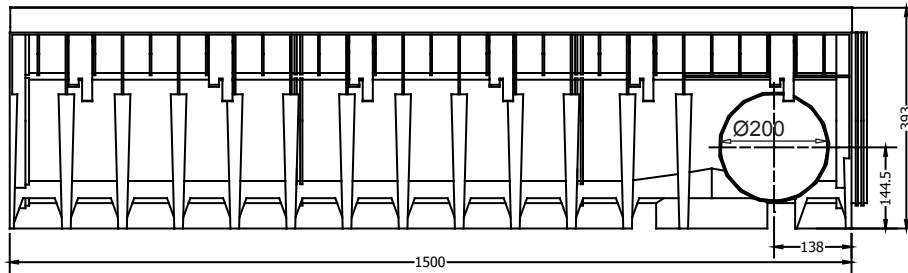

LATERAL VIEW

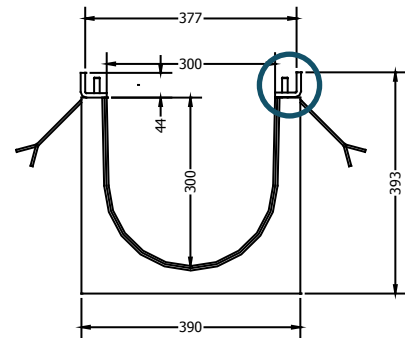

SECTION

**Watertight:** To ensure the watertight of the channels, it is advisable to use an adhesive bituminous sealing. As a complete and long lasting guarantee of absence of leakages through the joints of the channels, it is possible to hot-solder the joints

The products have to be installed according to MufleSystem's specifications.

## Data Sheet

### Dimensions and features

N.B. Dimensions and weights are subjected to the normal tolerances of the manufacturing

Length (mm)	1500
External width (mm)	390
External high (mm)	393
Internal width (mm)	300
Internal high (mm)	300
Outlets	3 x Ø200 - 3 x Ø160
Material	HD-PE
Material Edge	Galvanized steel (ductile iron on request)
Weight (Kg)	28.9
Drainage section (cm <sup>2</sup> )	796
Capacity (dm <sup>3</sup> = litres)	79.6

### Gratings

Slot 33x19	galvanized steel	Class C250
Mesh	ductile iron	Class C250, D400, E600, F900
Slot 20 mm	ductile iron	Class F900
Closed cover	ductile iron	Class E600